

A NOVEL BIDIRECTIONAL ELECTRIC-DRIVE-RECONSTRUCTED ONBOARD ANN CONTROLLED CONVERTER FOR ELECTRIC VEHICLES

M. Muthu Priya

*PG Scholar, Department of Electrical and Electronics Engineering
Pandian Saraswathi Yadav Engineering College, Sivagangai, Tamil Nadu*

D. Duraimurugan

*Assistant Professor Department of Electrical and Electronics Engineering
Pandian Saraswathi Yadav Engineering College, Sivagangai, Tamil Nadu*

Abstract

In this work, an Electric-drive-reconstructed onboard converter (EDROC) is presented. This vehicle is implemented with the highly advanced machine learning technique, namely Artificial Neural Network (ANN) and PI controller network. This system is used the previous components presented in electric vehicles (EV), and it would not require any additional hardware. This system can be easily implemented in all office, home, and restaurant environments. This EDROC has two modes, namely charging and driving mode. The charging is set the power factor unit, and the driving mode is used to drive the motor. Even though it is highly flexible for the implementation, it is less in cost and volume than the previous EV.

Keywords: EDROC, EV, charging and driving mode, ANN

Introduction

Due to an enormous amount of population growth in the current century, energy is consumed in an infinite number which can be highly demanded in society. For the reason of global warming, transportation is also the main reason for the last several decades. The fossil fuel requirements are in high number, and also the pricing is also increased to the extreme. Even though the fuel emits a lot of carbon which is the basic ingredient for ozone depletion. So transportation has to control the issues of carbon emission with some other alternates. This field of implementation should be addressing the environmental and energy crisis [1],[9].On the whole, considering these issues, the Governments are trying to implement an eco-friendly vehicle which is named Electric Vehicles (EV). This EV has overcome all the issues of vehicle emissions, national energy refuge, and domestic production growth.

The current status and future learnings are presented in propulsion innovations for EV. Electric mobility has illustrated a comparison between an EV and a fuel vehicle. But for higher efficiency, the EV should be implemented with an efficient control strategy in micro grids. Several methods are processed with a researcher that is associated with the issues of power quality and charging time requirements [2]. These are the main problems to implement an EV, and the charging station is implemented with the high micro grid that can be done by transferring power from Grid to Vehicle (G2V) and Vehicle to Grid (V2G). The control signals are handled with an energy box to be processed. The wind and solar power generation are generally supported to implement the G2V/V2G operating phases that are turned a residential area into a micro grid stand.

In this paper, the smart EV is presented with a bidirectional topology with the combination of ANN and PI control strategy for higher efficiency in power facton. This paper is organized with an introduction in section 1, and section 2 is discussed with related work. The preliminary of the present work is described in section 3, and section 4 illustrates the proposed strategy of ANN. Section 5 is the illustration of the results and discussion. Then finally, the paper is concluded with the conclusion and the references, respectively.

Related Work

In this section, the related works are discussed with the different researchers are implemented the similar concept about the EV are explained in the following. Presented a high-efficient non-isolated single-stage on-board charger for EV [8]. It comprises a 2-phase interleaved buck-boost converter and bridge rectifier that is highly efficient in charging a battery.

Developed a bidirectional 3-input DC-DC converter for EV. This system and also regenerative braking is also implemented [9]. Developed a Fuzzy logic controller (FLC) for EV with battery and PV cell. This FLC adjusted the battery power that reduces the damage, and also increasing the lifetime of EV [2]. Presented a Half-bridge with PI controller and Zero Voltage (ZV). This system has a Soft switching for DC motor and also a Bidirectional power indicated by the battery State of Charge (SoC) life increment [3].

Analyzed a system that has diodes and 4 switches with charging and discharging modes. Regenerative braking is applied to charge the sources relying on their voltage level [6]. Presented a converter that has 6 MOSFET and 2 inductors attached with boost inter leaving process. The operation of a synchronous rectifier is performed by 2 MOSFETs among 6 switches [11].

Developed a booster circuit for EV. The voltage in the battery is done by interleaved front-end converter. The DC link voltage is modified with the command speed. The fast DC voltage tracking and dynamic load responses are also implemented [12].

Preliminaries

In this section, the Electric-drive-reconstructed onboard converter (EDROC) is discussed.

Bidirectional Charger

The EDROC is a converter that is implemented with an auxiliary circuit connection that is given in figure 1. The inverter of traction hardware and auxiliary circuit that are generated a switching network to rebuild a converter. This strategy is suitable for all traction hardware with the three-phase inverter. It does not require a special motor and utilized a single-phase power supply, namely inductance or switch at the AC side. This method has two, namely charging mode and driver mode, which are given in the reference [1].

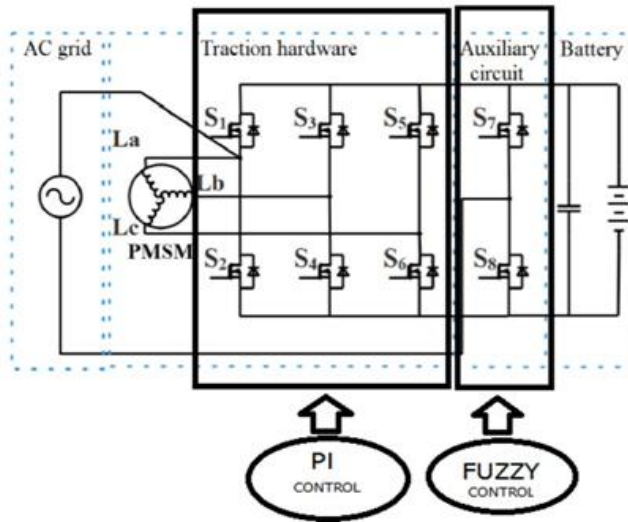

Figure 1. EDROC Topology

Charging Mode

In this mode, the switches of s3 to s8 are turned ON. And S1 and S2 are turned off. These switching states are partitioned into several states up to 8 operations. This is processed in states I — IV if grid voltage is positive and performs in states V- VIII if a voltage is negative. [10]

From [10], the connection between the input and the output voltage is expressed in the following

$$\begin{cases} G = \frac{1}{1-D} \\ V_B = mV_m G \sin(\omega t) \end{cases} \quad (1)$$

Where G indicates a voltage gain and V_m indicates an input voltage amplitude. The m shows the modulation index inverter.

Driving mode

From the ref [1], the switches of S1 -S6 are turned ON with the S7 and S8 are disabled in this mode. The PMSM electromagnetic torque in the d - q frame is expressed in the following:

$$\begin{cases} u_d = R_s i_d + P \psi_d - \omega_r \psi_q \\ u_q = R_s i_q + P \psi_q + \omega_r \psi_d \\ T_e = P (\psi_d i_q - \psi_q i_d) \end{cases} \quad (2)$$

where R_s indicates a stator resistance; i_d and i_q indicators d-axes stator currents and q-axes stator currents respectively; the ψ_d and ψ_q represented the permanent magnet flux linkage in d-axes and q-axes, respectively.

Proposed System

In this section, the proposed system of EDROC that is implemented with the control strategy of ANN and PI controller has been discussed.

ANN

In recent researches, the ANN strategy is one of the best in training the data set of a complicated non-linear system. The ANN represents an Artificial Neural Network that is simulated with an idea of the human brain and nerve interconnections. This system can be trained effectively to recover non-linear issues that are matched to the brain system. This ANN strategy can be implemented in several applications of the induction motor driving system. Some of the applications of current control are adaptive flux control, speed control, and field-oriented control.

The system model of EV is used with the ANN with first tapped delay lines using Signal Of controller (SOC), as it is shown in Figure 2. The next estimated output is the SOC[k+1] that is reverted on feedback values of the output (SOC[k], SOC[k-1], SOC[k-2]) and previous values of independent input signals like voltage (V), current (I) and the four temperatures (T1C, T2C, T3C, and T4C) respectively.

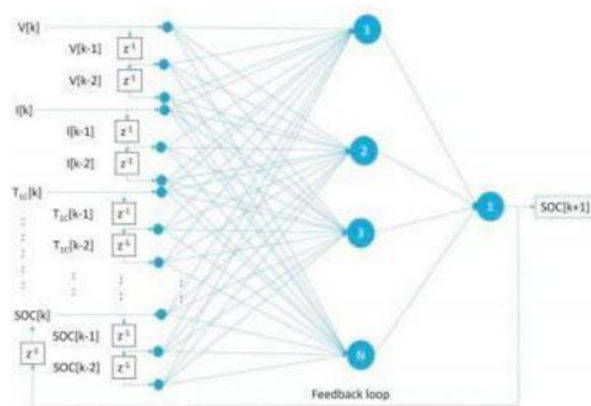

Figure 2 ANN for system model

The Training sets are performed in a series-parallel methodology, where the true output (SOC) is presented in this time period. This method can perform a static back propagation operation for improving the accuracy of the system. In the parallel scheme, the SOC estimation is fed back to the network during the validation and test stages.

PI Controller

The PI controller is termed as a Proportional Integral controller, which is a variation of Proportional Integral Derivative (PID) control. This controller is to custom only the proportional and integral of the system. This PI controller is the more efficient and popular variation than the PID controllers. The controller output $u(t)$ is fed into the system as the deployed variable input.

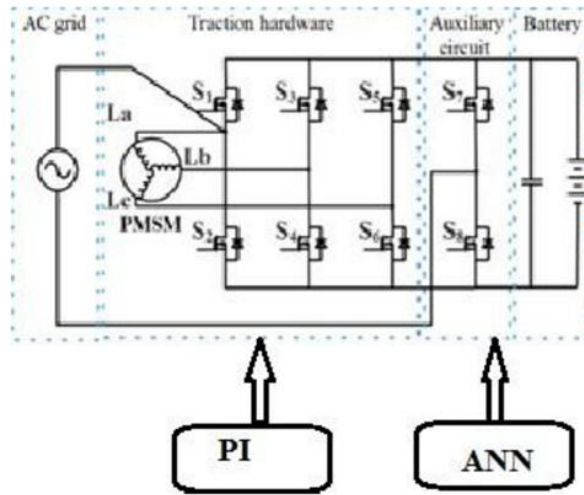

Figure 3. Proposed controller topology

ANN and PI based Charger Control

From figure 3, there are two outputs of the controller combined with the EDROC model. Initially, the EDROC signal is used to control the level of voltage through a rectifier between grid and DC capacitor. Next, the buck/boost converter is associated with the current controlling signal for controlling the charging current. Therefore, in EDROC the certain parameters are measured as the critical inputs. Generally, the error between the measured voltage and the present voltage is achieved. The measured error is observed by the ANN controller that reacts by generating phase shift angle. Then, the quadrature and direct voltages from the grid voltage are achieved. The actual voltage and desired direct voltage are compared by the ANN and PI controller. Then the error among the two given as input of ANN and PI Controller, that sets the magnitude of the required modulation signal.

Result and Discussion

In this section, the result is simulated and implemented using the MATLAB software is discussed in the following.

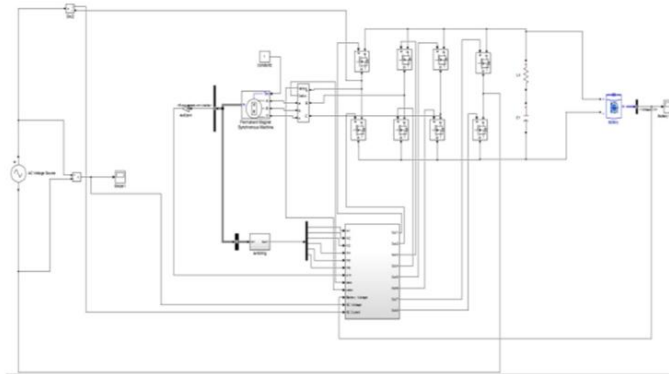

Figure 4 Charging mode

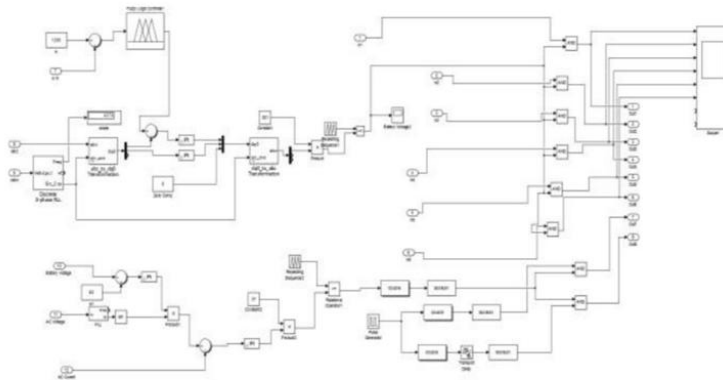

Figure 5 Controller section

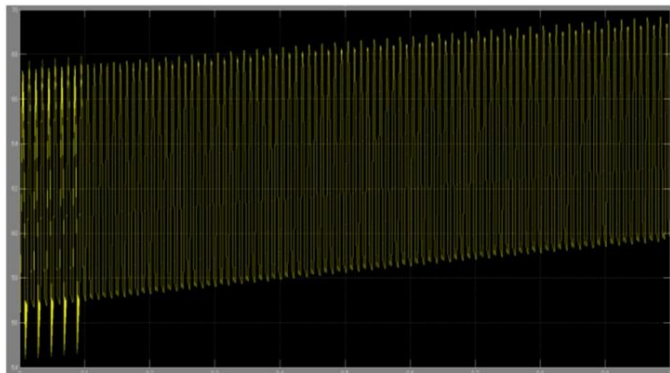

Figure 6 Battery voltage output

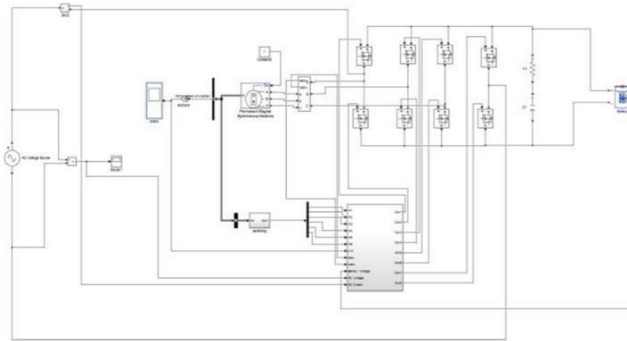

Figure 7 Driving mode

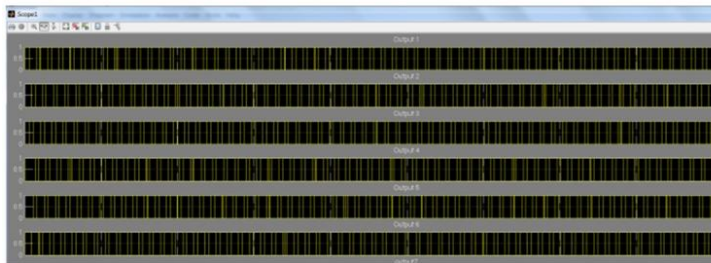

Figure 8 Controlling pulses

Conclusion

This work is based on EV, which is based on the ANN and PI controlled Electric-drive-reconstructed onboard converter (EDROC) is presented. This converter is simple and efficient than the previous method, which has no additional equipment. This can be modified from the three-phase motor drive converter that is so flexible for the power factor requirements. This can be associated with the power outlet at any places without any additional power supply. This system has minimum ripple suppression that is better than the previous converter. Therefore, the proposed topology has some merits include less size and minimum cost than traditional methods.

References

1. A Radhika, G Soundradevi, R Mohan Kumar., An effective compensation of power quality issues using MPPT-based cuckoo search optimization approach, *Soft Computing* 24 16719-16725
2. Adam, K. B., & Ashari, M., Design of bidirectional converter using the fuzzy logic controller to Optimize battery performance in Electric vehicles. In *International Seminar on Intelligent Technology and Its Applications (LSITIA)*, IEEE., (2015) 201-206. Akar, F., Tavlasoglu, Y., Ugur, E., Vural, B., & Aksoy, L, A bidirectional nonisolated multi-input DC-DC converter for

- hybrid energy storage systems in electric vehicles. *IEEE Transactions on Vehicular Technology*, 65(10) (2015) 7944-7955.
3. Lin, Y. S., Hu, K W., Yeh, T. H., & Liaw, C. M., An electric-vehicle IPMSM drive with interleaved front-end DC/DC converter. *IEEE Transactions on Vehicular Technology*, 65(6) (2015) 4493-4504.
 4. Liu, S., Xin, D., & Yang, L., A novel single-phase bidirectional electric-drive-reconstructed onboard converter for electric vehicles. *IEEE Access*, 8 (2020) 44739-44747.
 5. Monteiro, V., Pinto, J. G., & Afonso, J. L., Operation modes for the electric vehicle in smart grids and smart homes: Present and proposed modes. *IEEE Transactions on Vehicular Technology*, 65(3) (2015) 1007-1020.
 6. Morsalin, S., Mahmud, K., & Town, a, (November). Electric vehicle charge scheduling using an artificial neural network. In 2016 IEEE Innovative Smart Grid Technologies-Asia (ISGTAsia), IEEE, (2016) 276-280.
 7. Oh, C. Y., Kim, D. H., Woo, D. G., Sung, W. Y., Kim, Y. S., & Lee, B. K., A high-efficient nonisolated single-stage on-board battery charger for electric vehicles. *IEEE transactions on Power Electronics*, 28(12) (2013) 5746-5757.
 8. Rahila J, M Santhi., Integrated fuzzy and phase shift controller for output step voltage control in multilevel inverter with reduced switch count, *Automatika*, 61(2) 238-249.
 9. Sam, C. A., & Jegathesan, V., Bidirectional integrated on-board chargers for electric vehicles—a review. *Sadhana*, 46(1) (2021) 114.
 10. Tang, Y., Ding, W., & Khaligh, A., A bridgeless totem-pole interleaved PFC converter for plug-in electric vehicles. In *IEEE Applied Power Electronics Conference and Exposition (APEC)* (2016) 440-445. IEEE.
 11. Tashakor, N., Farjah, E., & Ghanbari, T., A bidirectional battery charger with a modular integrated charge equalization circuit, *IEEE Transactions on Power Electronics*, 32(3) (2016) 2133-2145.
 12. Tousi, S. R., & Sharifian, E, A bidirectional 3-input DC-DC converter for electric vehicle applications, In *23rd Iranian Conference on Electrical Engineering*, (2015) 1700-1704. IEEE.
- Trigg, T., Telleen, P., Boyd, R., Cuenot, F., D'Ambrosio, D., Gaghan, R., & Jones, A. R. *Global EV Outlook: Understanding the electric vehicle landscape to 2020*. Int. Energy Agency, 1 (2013) 1-40